

1 Division 2 and 3 sword construction

This describes one method for the construction of an Atlantian youth combat weapon for divisions 2 and 3. While there are variations on this technique and other techniques, following these instructions should produce a weapon that is legal for youth armored combat in Atlantia.

1.1 Materials

$\frac{3}{4}$ inch I.D. schedule 40 PVC
 $\frac{3}{4}$ inch PVC cross connector
(4) PVC end caps for $\frac{3}{4}$ inch I.D. Schedule 40 PVC
Strapping tape
Duct tape in 2 contrasting colors
Foam pipe insulation
Hockey grip tape (optional)

1.2 Cut the PVC to length

Cut one piece of PVC no longer than 26 inches for the blade. The 26 inches is not a rule, but more of a practical limit. For a tall teenager, the 26 inches may be longer. Cut two very short pieces for the quillions. Cut one more piece for the handle. Assemble the pieces with the cross connector and an end cap on each end. You should tap the pieces together with a rubber mallet or hammer whether you use PVC cement to secure them or not. If you do not use PVC cement it is more important to be sure the pieces are snug together.

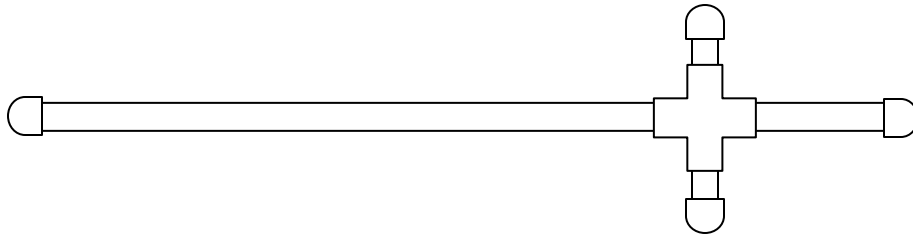

1.3 Cover in strapping tape

Cover all the PVC completely in strapping tape. Use lengthwise strips and wrap circular bands around pieces only to secure the ends of lengthwise strips around joints if you didn't cement the PVC together. Completely cover the PVC in a lateral layer of strapping tape. No PVC must show at all. Wrap a second layer of strapping tape using a spiral wrap. This creates two layers of strapping tape that crisscross each other

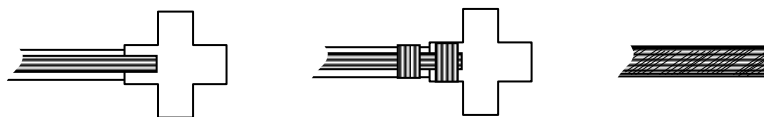

1.4 Cover the sword in foam pipe insulation

Take a piece of pipe insulation that is the length of the blade plus about 3 inches. Cut 2 notches in this piece of pipe insulation that are approximately $\frac{3}{4}$ of an inch long and

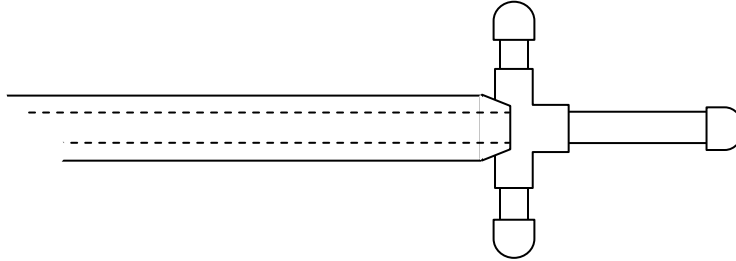
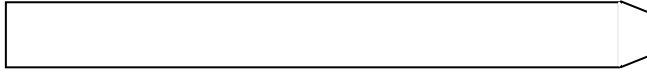

about $\frac{1}{2}$ an inch deep. Slide this piece of foam pipe insulation over the blade.

Cut 2 more pieces a little longer than the quillions and notch them like the piece on the blade. Slide them over the quillions so that they meet the piece on the blade. When you are done the foam should extend at least $\frac{1}{2}$ inch past the quillion

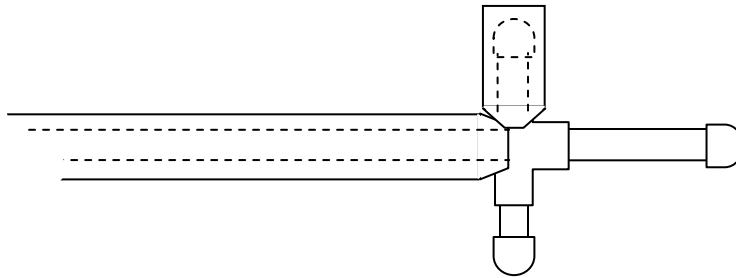

There is a seam in the pipe insulation that will separate and leave a gap. This is true especially over the end caps and cross connector. Do not attempt to slide the foam pipe insulation over the PVC without allowing the slit to expand as this will compress the foam.

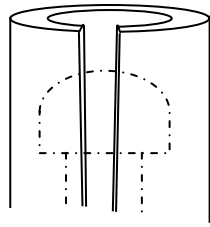

Slide the foam down all the way to the quillions. Allow 2.5 inches past the tip of the PVC end cap for a thrusting tip and trim the foam with scissors. Take another piece of foam pipe insulation and cut a length wise strip to fill in the gap from the seam in the piece of foam on the PVC. It does not have to be one continuous strip. As you make the strip for the section past the tip cut the strip in an increasing width to make a slight wedge. This will increase the diameter at the tip to meet the 2.5 inch diameter requirement for the thrusting tip and also cover the increased diameter of the end cap.

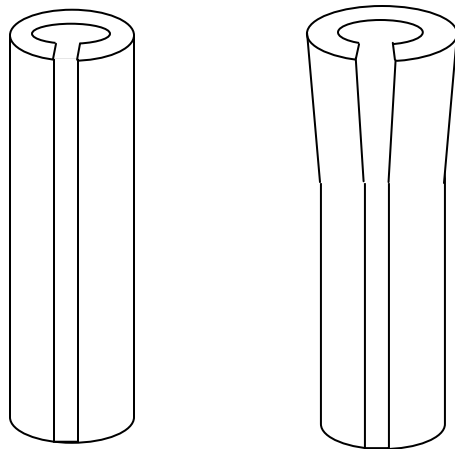

Secure the foam to the sword with tape. Secure the strip of foam in between the seam edges of the main foam piece with tape. Put foam around and on the quillions. Make the foam extend $\frac{1}{2}$ inch past the end caps. Make a foam pommel to cover the end cap at the end of the handle. It should extend $\frac{1}{2}$ inch past the PVC end cap.

There should now be a gap at the tip where the cylinder of foam extending beyond the tip of the PVC end cap is hollow. Chunks of foam can be torn or cut and inserted into the tip to fill it with foam. Try to make the tip as flat as possible. Do not pack the tip or pre-compress the foam. Fill it loosely and secure the end with a little tape.

1.5 Cover the sword in duct tape

Cover the sword in duct tape using long length wise strips. You can skip the handle and optionally tape it with hockey grip tape. Besides the handle, cover the entire sword including the pommel. Do not wrap the tape or compress the foam, but loosely place the strips of tape. Take a long strip of duct tape, as long as the blade, in a contrasting color, and tear it in half length wise. Use these two narrow strips to mark the edge of the blade. Use more duct tape in the contrasting color to mark the thrusting tip.

